

Parametric Study of Drag on Orientation of High Rise Building

Prof. Amol .S. Pote * and Mrs. Smrutirekha Mishra **

* Department of Civil Engineering, G. H. Raisoni College of Engineering and Management, Pune 412207, India
amol.pote@raisoni.net

** Research Scholar, Department of Civil Engineering, G. H. Raisoni College of Engineering and Management,
Pune 412207, India
smruticeb@yahoo.co.in

Abstract: In India high rise buildings are becoming a common feature of urban landscape. Limited information is available regarding wind flow around such buildings. Effect of wind is predominant on structure depending on location, orientation of building. The flow is affected by architectural features. In this work a rectangular building is studied under the effect of wind force and how orientation affects the wind load on tall buildings shall be studied based on wind tunnel tests with rigid models, Wind pressure distributions on building with different aspect ratio will be measured and analyzed. The investigations can offer some basic understanding for estimating wind load distribution on building & facilitate wind resistant design of cladding components & their connections considering wind load.

It is also proposed to study the interference when two tall buildings are built side by side. The study will involve different orientations & separating distance between the two tall buildings. Models will be tested in wind tunnel for different angles of orientation & different wind speeds.

Keywords: Damping, Rectangular building, structural dynamics, wind force, wind tunnel.

Introduction

Wind is a phenomenon of great complexity because of the many flow situations arising from the interaction of wind with structures. Wind is composed of a multitude of eddies of varying sizes and rotational characteristics carried along in a general stream of air moving relative to the earth's surface. The emergence of modern materials & construction techniques resulted in structures that are often to a degree unknown in the past, remarkably low in damping, & light in weight. Generally such structures are more affected by the action of wind. The structural should ensure that the structure should be safe & serviceable during its anticipated life even if it is subjected to wind loads. Wind forms the predominant source of loads in tall free standing structures. The effect of wind on tall structure can be divided into two components they are

- Along wind effect
- Across wind effect

Along wind loads are caused by the drag components of the wind force whereas across wind loads are caused by the corresponding lift components.

An important problem associated with wind induced motion of buildings is concerned with human response to vibration and perception of motion. Therefore, for most tall buildings serviceability considerations govern the design and not strength issues.

Wind Speed

At great heights above the surface of the earth, where frictional effects are negligible, air movements are driven by pressure gradients in the atmosphere, which in turn are the thermodynamic consequences of variable solar heating of the earth. This upper level wind speed is known as the gradient wind velocity. In practice, it has been found useful to start with a reference wind speed based on statistical analysis of wind speed records obtained at meteorological stations throughout the country.

Design Wind Loads

The characteristics of wind pressures on a structure are a function of the characteristics of the approaching wind, the geometry of the structure under consideration, and the geometry and proximity of the structures upwind. The pressures are not steady, but highly fluctuating, partly as a result of the gustiness of the wind, but also because of local vortex shedding at the edges of the structures themselves.

The complexities of wind loading, should be kept in mind when applying a design document. Because of the many uncertainties involved, the maximum wind loads experienced by a structure during its lifetime, may vary widely from those assumed in design. Wind loading governs the design of some types of structures such as tall buildings and slender towers. It often becomes attractive to make use of experimental wind tunnel data in place of the coefficients given in the Wind Loading Code for these structures.

Types of Wind Design

Typically for wind sensitive structures three basic wind effects need to be considered.

1. Environmental wind studies
2. Wind loads for façade
3. Wind loads for structure
4. Design Criteria

In terms of designing a structure for lateral wind loads the following basic design criteria need to be satisfied.

- a. Stability
- b. Strength
- c. Serviceability

Static Analysis

This method assumes the quasi-steady approximation. It approximates the peak pressures on building surfaces by the product of the gust dynamic wind pressure and the mean pressure coefficients. The mean pressure coefficients are measured in the wind-tunnel or by full-scale tests.

The quasisteady model has been found to be fairly reliable for wind loading on small structures.

In static analysis, gust wind speed (V_z) is used to calculate the forces, pressures and moments on the structure.

Along and Cross-Wind Loading

The wind approaching a building a complex phenomenon, but the flow pattern generated around a building is equally complicated by the distortion of the mean flow, flow separation, the formation of vortices, and development of the wake. Large wind pressure fluctuations due to these effects can occur on the surface of a building.

Under the collective influence of these fluctuating forces, a building tends to vibrate in rectilinear and torsional modes, as illustrated in Fig. 1. The amplitude of such oscillations is dependent on the nature of the aerodynamic forces and the dynamic characteristics of the building.

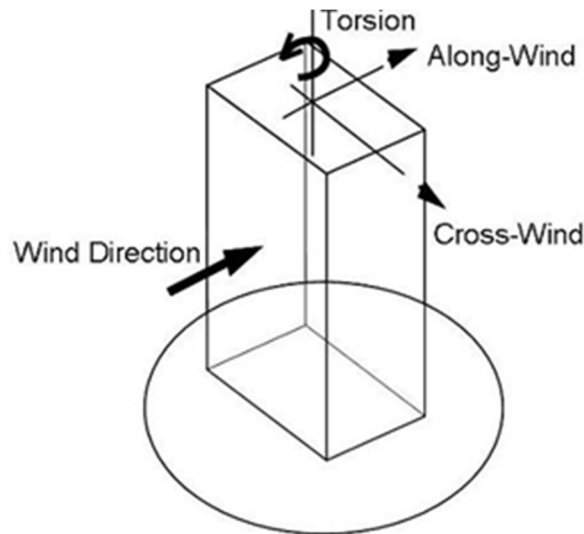

Figure 1. Wind Response Directions

Along-Wind Loading

The along-wind loading or response of a building due to buffeting by wind can be assumed to consist of a mean component due to the action of the mean wind speed (eg, the mean-hourly wind speed) and a fluctuating component due to wind speed variations from the mean.

Cross-Wind Loading

There are many examples of slender structures

That are susceptible to dynamic motion perpendicular to the direction of the wind. Crosswind excitation of modern tall buildings and structures can be divided into three mechanisms (AS/NZ1170.2, 2002) and their higher time derivatives, which are described as follows:

- a) Vortex Shedding.
- b) The incident turbulence mechanism.
- c) Higher derivatives of crosswind displacement.

Wind Tunnel

There are many situations where analytical methods cannot be used to estimate certain types of wind loads and associated structural response. Wind tunnel testing is now common practice for design of most tall buildings. It is a tool which is used in aerodynamic research to study various effects of air moving on solid objects. It consists of a tubular passage with an object under test which is mounted in the middle position of tunnel. Air is made to move over the object by a powerful suction fan system. The test object is also called a wind tunnel model consists of suitable sensors which is used to measure aerodynamic forces & outlet velocity & a manometer to measure pressure distribution over the object surface. The wind tunnel used is of suction type with an axial flow fan powered by a suitable motor. Wind tunnel testing is used in design of most major tall buildings to identify the wind induced structural loads and responses for which the superstructure has to be designed. The first wind engineering task for the engineer is to determine whether to design according to local conditions i.e. local wind loading code or standard, or to employ wind tunnel testing results, so it is advised to just analysis the result of wind tunnel for a structure and implement them with local condition codes using coefficients.

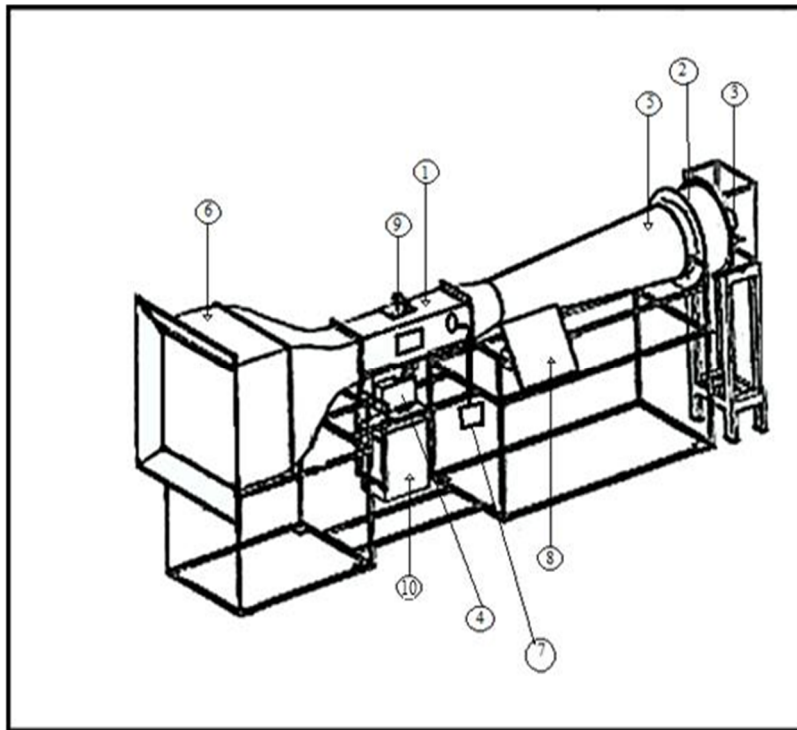

Fig 2: Wind Tunnel

Table 1. Specification of Wind Tunnel

Sr no.	Type	Open type wind tunnel
1	Test section	-
	Main Duct	Ms with powder coating
	Side glass material	Acrylic Sheet- 8mm Thick.
	Size	300mm x 300mm X1000mm long
2	Blower Fan	5 Blades- Aluminum Die cast
3	A.C. Motor	3 H.P. -2880 RPM
	Speed Variation	10% to 100% by frequency Drive Controller
4	Strain Gauge	Two Channel, Digital display
	Balance	Lift force 0-20 Kg
		Drag force 0-20 Kg
	Lift/Drag force sensor	0 to 20 Kg beam type load cell
5	Diffuser section	-

Wind Tunnel Tests

Wind tunnel tests Wind tunnel testing is a powerful tool that allows engineers to determine the nature and intensity of wind forces acting on complex structures.

Wind tunnel testing is particularly useful when the complexity of the structure and the surrounding terrain, resulting in complex wind flows, does not allow the determination of wind forces using simplified code provisions.

The facility is a closed circuit, single return tunnel with a 7 ft wide by 5 ft high by 25 ft long test section. With a contraction ratio of 15:1 and the use of multiple diffusion screens, very low turbulence is achievable. The tunnel is capable of continuous operation at velocities of over 150 mph. large windows on the side and top of the test section allow for excellent model viewing. Force and moment data are obtained from a below-floor balance system capable of supporting models having gross weights of over 300 pounds. It resolves all six force and moment components to an accuracy of one part in 3,000, with less than 0.1 percent interaction error.

The wind tunnel facility also has instrumentation for the measurement and recording of operating pressures, the angle of attack or angle of yaw, tunnel static pressure, dynamic pressure and temperatures. A computer/data acquisition system is used to average and record the results. Boundary layer velocity profiles on the tunnel walls or on the model can be obtained via Pitot tubes or hot wire probes.

The laboratory has extensive facilities for flow visualization. The introduction of helium-filled bubbles or smoke into the flow, small vanes mounted on a given surface to show flow direction, coating the model with oil and the use of tufts are some of those methods. Photographic systems from still to motion (5 frames/sec up to 1 million frames/sec) are available. Video cameras and recorders are also available.

Wind Tunnel Instrumentation

Pitot tube Pitot tube is the basic instrument used for measuring wind speed in a wind tunnel

Hot-Wire Anemometer used to measure both mean velocity and turbulence. They can measure rapid changes of velocities with frequency response higher than 1 kHz

Bell Mouth and Entry the entry is shaped to guide the air smoothly into tunnel.

Test Section Working section consists of 300mm x 300mm x 1000mm test section with two windows to insert the models or probes

Diffuser Section Diffuser reduces dynamic pressure which, leads to reduction in power losses at the exit.

Axial Fan and Motor

Which gives smooth variation of air velocity in the test section which can be seen on the anemometer or Pitot tube and one can set the velocity of air to desired level.

Smoke generator

A smoke generator and probe that allows students to see air flow in subsonic wind tunnels and other low flow rate air flow products. It is a control unit that pumps oil to the tip of a probe.

Results and Discussion

Building Geometry & Experimental details

A 50 storey building $H=150$ m tall prototype building has a rectangular cross section with constant dimension $45.72\text{m} \times 30.48$ m over the building height.



Figure 3 : Building Model with pressure tappings

The x & y are normal to long & short sides of the rectangle respectively .The direction of the wind speed is defined by counter clockwise angle with respect to y axis .the experiments will be conducted in wind tunnel.

Codes and Standards

The AISC Specifications (AISC 1978) contains a provision in Section 1.3.5, Wind, requiring that "proper provision shall be made for stresses caused by wind, both during erection and after completion of the building.

Risks

The tacit attitude seems to prevail in the design/construction industry that structural integrity during construction is less important than in permanent structures, therefore greater risks are acceptable.

There are various means, during the planning-design- construction process, of controlling the wind created risks:

1. During the planning phase Establishment
2. During the design phase
3. During the construction phase

Wind-Structure Interaction

Wind-structure interaction depends on many factors such as the size and shape of the structure, on the exposure and shading of the components and on the dynamic characteristics of the structure. All these factors are very different during construction than after completion of the project. Some elements, such as temporary support and access structures, do not even exist after completion. Not only are these factors different but they continually change during the day-to-day progress of the work.

Projected areas are generally less during construction than after completion: for example, a structure skeleton versus the enclosed building. But these wind areas in their temporary configurations generate different force coefficients and give rise to different gust response factors than the enclosed building does. The wind-structure interaction terms of force coefficients and gust response factors in ANSI and other codes were developed for complete structures of regular shapes.

At present, the best an engineer can do is calculate and sum up in a conservative manner the wind forces on all individual components exposed to the wind, or, if the funds and time are available, perform wind tunnel tests of the most vulnerable configurations anticipated during the construction.

Conclusion

After the observation it has been concluded that In long wall wind pressure remains constant with alternate pressure tappings i.e. 0 & 60 degree and vice versa. At the highest point pressure may be changed with angle 30, 45 & 60 degree that depends on aspect ratio. In short wall wind pressure increases towards increasing the height of building with angle of orientation .At bottom pressure changes with constant angle of orientation 45 degree.

References

- [1] Wind Design Problem S With Building Structure S Durin G Construction By Robert T. Ratay,1 Fellow, Asce
- [2] Ratay, R. T., And Suprenant, B. A. (1987). "Assessment And Control Of Wind Created Risk During Construction." Proc. Of Risk Assessment Of Constructed Facilities Under Wind, Dynamics Of Structures, Asce Structures Congress '87, Orlando, Fla., August.
- [3] Mehta, K. C. (1983). "Use Of Ansi A58.1 For Solar Collector Wind Loads." Asce Preprint 83-507, Houston, Tex., Oct. 17-19.
- [4] Wind Loading On Tall Buildings P. Mendis, T. Ngo, N. Haritos, A. Hira The University Of Melbourne, Australia , B. Samali University Of Technology Sydney, Australia J. Cheung Monash University, Australia
- [5] As/Nz1170.2 (2002) Australian/New Zealand Standard, Structural Design Actions, Part 2: Wind Actions, Standards Australia & Standards New Zealand.
- [6] Tamura Y., Ohkuma, T., Okada, H., Kanda, J. (1999) Wind Loading Standards And Design Criteria In Japan, J. Wind Engineering And Industrial Aerodynamics , 83, 1, 555-566.
- [7] Cooney R.C. And King, A.B. (1988) Serviceability Criteria Of Buildings
- [8] Ansi Code (1982). Ansi A58.1-1982. Minimum Design Loads For Buildings And Other Structures. American National Standards Institute
- [9] Soong T.T. And Costantinou, M.C. (1994). Passive And Active Structural Vibration Control In Civil Engineering. New York: Springer